

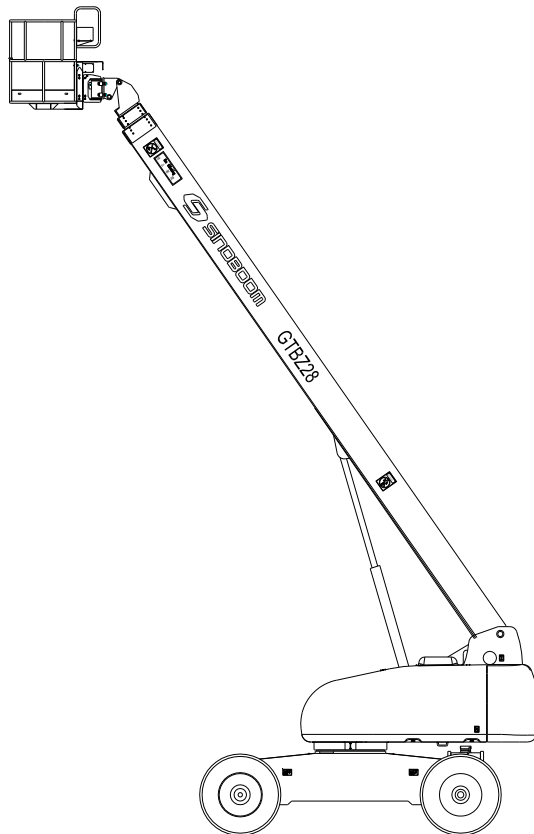

Hunan Sinoboom Heavy Industry Co., Ltd.

Operation Manual

GTBZ-28



© Copyright by Hunan Sinoboom Heavy Industry Co., Ltd.

The second edition: Sep, 2009

Contents

Importance.....	1
Safety Rules.....	2
1.1 Electrocution Hazard	2
1.2 Tip-over Hazard	3
1.3 Falling Hazard	6
1.4 Crush Hazard	6
1.5 Damage Hazard to the Parts	7
1.6 Explosion and Fire Hazard.....	8
1.7 Damage Hazard to the Machine	8
1.8 Body Injury Hazard	8
1.9 Safety of the Weld Line to the platform	8
2. Label Definition.....	9
3. Control Panel.....	10
3.1 Controller panet on the turntable.....	10
3.2 Controller Panel on platform	11
4. Inspection before operation	12
4.1 Basic procedures.....	12
5. Maintenance.....	15
5.1 Label Definition for Maintenance.....	15
5.2 Check the engine oil level.....	16
5.3 Check the hydraulic oil level	16
5.4 Check the battery	17
5.5 Check the engine coolant level and type.....	18
5.6 Periodical maintenance	18
5.7 Timetable.....	18
5.8 Maintenance & Repair Reports	19
6. Function Test.....	19
6.1 Basic Principle.....	20
6.2 For the Turntable Controller	20
6.3 For the platform controller.....	21
7. Inspect the Workplace	24
8. Operation Preconditions	25
9. Lifting and transportation	28
10. Label.....	31

Importance

You shall read, understand and obey the related safety rules and operator's manual before any maintenance or repair procedures are to be done on the GTBZ28.

This manual is for GTBZ28

This manual is to provide detailed maintenance instruction for the owner and manufacturer of the product and solutions and procedures to the faults inspection and maintenance for the qualified servicemen.

It shall first know the basic information about the mechanism, hydraulic and electricity to carry out the maintenance procedures; and some particular skills, tools, lifting devices and suitable work places will be required for some maintenance procedures meanwhile. Thus, it is recommended to maintenance and repair the product in the assigned service centers by Sinoboom.

Sinoboom will greatly provide you with the accurate information and excellent service. However, it is Sinoboom's policy to constantly improve our products and the technical specifications may vary without notice, so please update your maintenance books timely.

Sinoboom encourages the readers to inform us the defects and provide the solutions and we will carefully consider all the opinions and make it as the reference for the maintenance books the other manuals revise and updating.

Please be free to contact Sinoboom if you get any question for Sinoboom products.

Contact information

Internet: www.sinoboom.com

Email: overseas@sinoboom.com

Telephone: 0731-85252820 Fax: 0731-85252826

© Copyright by Hunan Sinoboom Heavy Industry Co.,Ltd.

The second edition: Sep, 2009

Safety Rules



Danger

It will cause death or serious injury if failed to obey the instructions and safety rules in this manual.

Do NOT operate unless:

- You understood fully and operated the safe operation rules in this manual.
 - 1、 Avoid dangerous situations.
Knew and understood the above rules before going to next steps
 - 2、 Inspect the machine before operation.
 - 3、 Test the functions before operation.
 - 4、 Inspect the workplace before operation.
 - 5、 Only use the machine as per its design intention.
- Should read, understand and obey the instruction and safety rules by manufacturer—safety manual, operation manual and the pasted labels on the machine.
- Should read, understand and obey the operator's safety rules and workplace rules.
- Shall read, understand and obey all the applicable rules by the related government.
- You are trained about the safe operation to the machine.

1.1 Electrocutation Hazard

This machine is NOT insulated, and it provides NO electrocutation protection.

Keep away from the power lines and machine according to the governmental regulars and the instructions in the table below.



Voltage (phase to phase)	Min. safety distance (m)
0 to 300V	NO touch
300V to 50KV	3.05
50KV to 200 KV	4.60
200KV to 350 KV	6.10
350KV to 500 KV	7.62
500KV to 750 KV	10.67
750KV to 1000 KV	13.72

When operating the machine, it should take the machine and platform movements into account, as well as the effect on the safety distance by the cables swing or loosen in the strong wind or gusty wind.

Please keep away from the machine if the machine is connected to the live cables. No touch by the persons on the ground and NO operation by the persons in the platform before the power are cut off.

Do not use the machine to weld, unless the machine is installed the weld line options to the platform and installed correctly.

1.2 Tip-over Hazard

It shall not exceed the max. platform capacity for the persons, devices and materials.

GTBZ28

Unlimited	250kg
Limited	480kg
Persons allowed max. 2	

The boom can only be lifted or extended when the machine is on the solid and flat ground.



Do NOT regard the tilt alarm as the level indicator. The tilt alarm on the platform will sound when the machine is severely tilted.

If the tilt alarm sounds:

- ※ Do not extend, rotate the boom or vary its amplitude.
- ※ Move the machine to the solid and horizontal ground.
- ※ Carefully enough stow the boom and drop down the platform if the tilt alarm sounds as the platform is lifting.
- ※ Do NOT rotate the boom during the dropping process. Move the machine to the solid and horizontal ground before lifting the platform.
- ※ Do NOT use the platform controller to release the platform when it is tripped, clipped or hindered its normal movements by other nearby objects. If the platform is planned to be released by the ground controller, it shall be not operated until all people leave the platform.
- ※ Do NOT operate the machine in strong or gusty wind. Do NOT increase the area of the platform or loads which is exposed in the wind, otherwise it will reduce the stability of the machine.



※ When stowed, it shall be driven extremely carefully and slow down the drive speed on the uneven or steep slope areas, unstable or slippery ground with gravel or near the cave, etc.

※ When boom raised or extended, it shall NOT be driven on or near the slope, unstable ground or other dangerous conditions.

※ Do NOT change, or forbid using the limit switch.



Do NOT push or pull any objects outside the platform.

Max. allowable force

Lateral force — CE

400N

※ Do NOT change, or forbid adopting any components which may influence the safety and stability.

※ Do NOT adopt the components which vary the weight or specifications from the key components to replace them, which may influence the stability.

※ Do NOT modify or amend the aerial work platform without the written permission by the manufacturer. It will increase the platform weight and platform surface area or loads if some additional devices which are used to place tools or other materials are installed on the platform, footswitch or guardrails.



※ Do NOT lay or tie some overhung loads on any parts of the machine.

※ Do NOT place the ladders or scaffoldings inside the platform, or any parts close to the machine.

※ Do NOT use the machine on the moving vehicles or other moving ground. Be sure that all tires are in good condition and slotted bolts are screwed tightly.

1.3 Falling Hazard

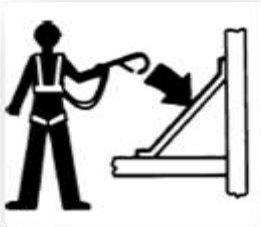

Every person to enter the platform shall wear the safety belt or use other security devices in accordance with the governmental regulations. And all the lacing wires shall be tied at some fixed points on the platform.

※ Do NOT sit in, stand on or climb the guardrails on the platform. Persons in the platform shall stand steadily on the bottom plate at any time.



When lifting the platform:

Do NOT climb down the platform or boom.

Keep NO barrier on the bottom plate of the platform.

Lay down the mid-rail of the platform guardrails or lock the entrance gate before operation.

1.4 Crush Hazard



It should pay attention to the objects in the range of visibility and blind spots.

When rotating the turntable, please take care of the position of the boom and the tailswing of the turntable.

Inspect the working area, to prevent bumping heads on the barriers or other possible crush hazard occurred.



Beware of the danger of being squeezed when gripping the guardrails of the platform.

Observation and use: there are circular and square marks and arrows in red and yellow indicating the driving and steering directions on the control panel of the platform controller and drive chassis.

Operators shall obey the related rules for operators to use life security devices, working place rules and governmental regulations.

Do NOT dangerous driving or making fun on operation.

Do NOT operate the boom on any crane route unless the crane controller has been locked and/or taken precautions to prevent any potential crush hazard.

It cannot lift down the boom until there is NO person or barrier in the area underneath.



It shall limit the travel speed according to the ground condition, crowdedness, slope grade, person position and other possible factors may cause crush accident.

1.5 Damage Hazard to the Parts

Do NOT adopt any battery or charger over 24V to start the engine.

Do NOT use the machine as earth wire for welding.

1.6 Explosion and Fire Hazard

Do NOT start the engine if any liquefied petroleum gas(LPG), gasoline, diesel fuel or other explosive materials are smelt or detected.

Do NOT fill the fuel when running the engine.

It shall not fill the fuel and charge the battery unless it is in the open and well-ventilated area which is also away from fire sources such as sparkle, flame and lit cigarettes etc.

Do NOT use the machine in the area which is dangerous or full of flammable or explosive gas or particles.

Do NOT jet the ethyl ether into the machine with glow plug engine.

1.7 Damage Hazard to the Machine

Do NOT use the damaged or faulty machine.

For each work transferring, it should fully check the machine before operation and test all the functions. The damaged or faulty machine should be marked and no operation allowed.

Be sure that it has completed all the maintenance operation according to this manual and related maintenance manual.

Be sure that all the labels are in correct position and easy to be indentified.

Be sure the operator's, safety and responsibilities manuals are complete, legible and in the storage container located on the platform.

1.8 Body Injury Hazard

Do NOT operate the machine if it leaks the hydraulic oil which may sink into or burn the skin.

Keep the machine always operated in the well-ventilated area to prevent the carbon monoxide poisoning.

It will cause bad injury by touching any parts under the broad plate by error. Only the trained maintenance people can check the bulkheads. Suggestion: the operators can inspect and repair the machine only when doing the inspection to the machine before operation. During the inspection, all the bulkheads shall be closed and locked.

1.9 Safety of the Weld Line to the platform

It should read, understand and obey all the attached warnings and instructions for the

welding devices.

It can contact the weld lines or cables only when the welding devices are turned off through the platform controller.

It can be operated when the welding cables are correctly contacted.

Contact the positive conductor to the torsion lock connector on the turntable and platform.

Contact the negative conductor to the ground pole on the turntable and platform.

2. Label Definition

Sinoboom labels, color codes and symbols indicate as following:



Safety warning symbol—to indicate the potential body injury. It shall obey all the safety tips of the label, to prevent the possible injury or death.



Red—to indicate the dangerous or urgent situation occurred, which would result in death or bad injury if it is not avoided.



Orange—to indicate the potential dangers existing, which would result in death or bad injury if it is not avoided.



Yellow and safety warning symbol—to indicate the potential dangers existing, which would result minor or some body injury if it is not avoided.



Yellow without safety warning symbol—to indicate the potential dangers existing, which would result in property

NOTICE

Green—to indicate the operation or maintenance instruction.

3. Control Panel

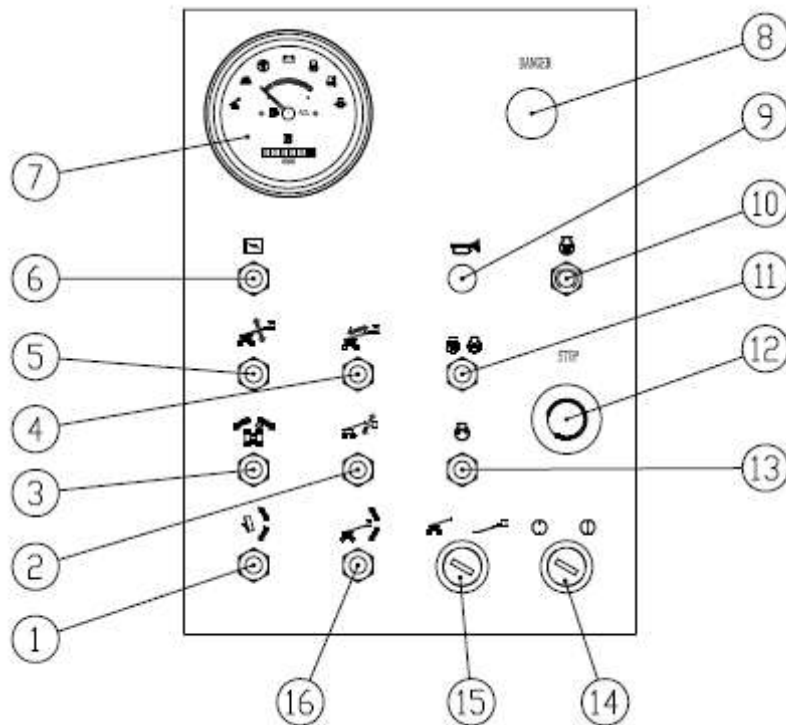

3.1 Controller panel on the turntable

- | | |
|--------------------------------|----------------------------------|
| 1. Rotation switch on platform | 9. Horn button |
| 2. Switch for boom up/down | 10. Engine preheating switch |
| 3. Switch for turntable rotary | 11. Engine high/low speed switch |

- 4. Switch for boom extend
- 5. Switch for boom amplitude variety
- 6. Auxiliary power switch
- 7. Engine state apparatus
- 8. Buzzer
- 12. Emergency stop button
- 13. Engine start switch
- 14. Power key switch
- 15. Switch for turntable and platform control shift
- 16. Manually-leveling switch for platform

3.2 Controller Panel on platform

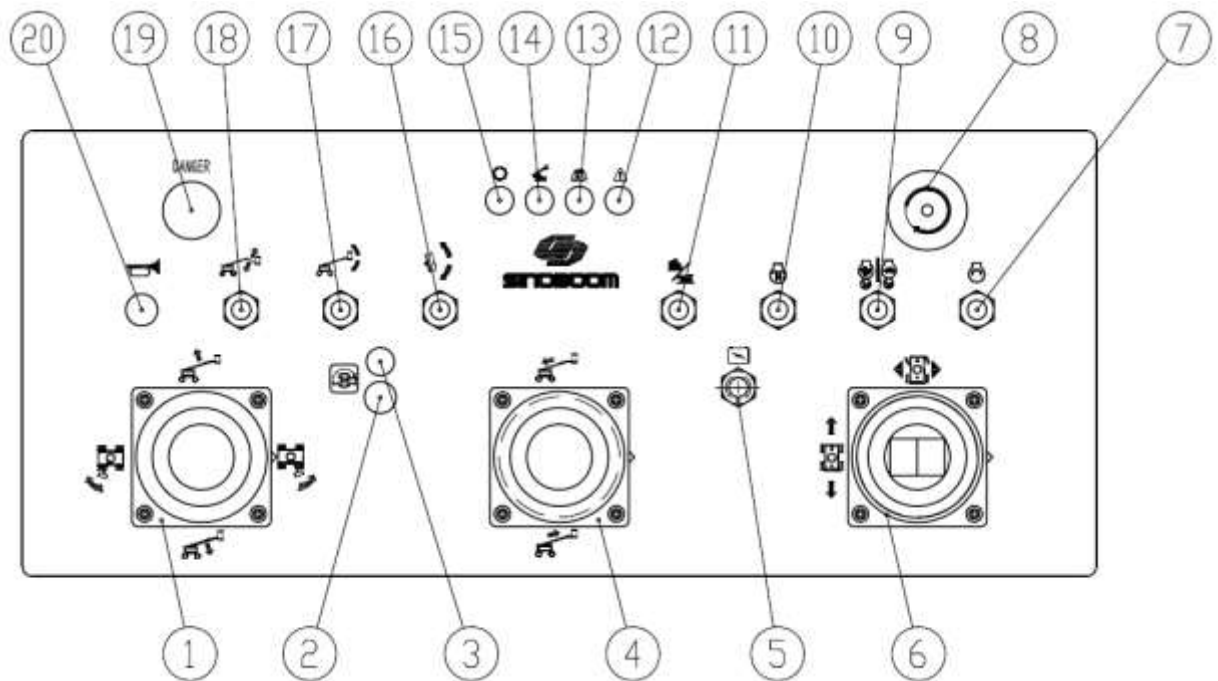

- | | | | |
|--|--|--|------------------------------|
| 1. Control handle for rotation and amplitude variety | 6. Control handle for driving and steering | 11. Switch for driving high/low speed shift | 16. Platform rotation switch |
| 2. Driving power button | 7. Engine start switch | 12. Alert indicator light for engine failure | 17. Manually-leveling switch |
| 3. Indicator light for rear area | 8. Emergency stop button | 13. Alert indicator light for overload | 18. Switch for jib up/down |

4.	Extend control handle	9.	Engine high/low speed switch	14.	Alert indicator light for tilt turntable	19.	Buzzer
5.	Auxiliary power switch	10.	Engine preheating switch	15.	Failure alert indicator light	20.	Horn button

4. Inspection before operation



Do NOT operate, unless:

- ✓ You have known and practiced the safe operation rules in this manual.
 1. to avoid dangerous situation occurred.
 2. always to inspect before operation
 - to understand and know clearly the rules above before next steps.
 3. Always to do the function tests before operation.
 4. to inspect the work place.
 5. Only to use the machine as per its design intention.

4.1 Basic procedures

It is every operator's responsibility to inspect before operation and regular maintenance.

It is an intuitive process to inspect before operation and shall be carried out by operators before every shift. It aims to check whether there are obvious problems in the machine before operators test functions.

It can be sure whether the regular maintenance procedures are needed via inspection before operation. It can be only carried out the regular maintenance procedures by the

operators.

Please search the list in the following page to check whether there is any part changed, damaged, loosened or missed in every item and position.

It is not allowed to use the damaged or amended machines. It shall mark the machines and stop using when any difference or damage is found from its release.

Only the qualified technicians can repair the machines according to the rules by manufacturer. The operators shall inspect the machine before operation again after the repair when testing the functions.

In accordance with the requirements by manufacturer and listed in the responsibility manual, it should be carried out the periodical maintenance and repair by the qualified technicians.

- Be sure the operator's, safety and responsibilities manuals are complete, legible and in the storage container located on the platform.
- Be sure the operator's, safety and responsibilities manuals are complete, legible and in the storage container located on the platform.
- Check whether the engine fuel leaks or it is at a suitable level and fill it when required. Please see to the "maintenance" part.
- Check whether the hydraulic oil leaks or it is at a suitable level and fill it when required. Please see to "maintenance" part.
- Check whether the engine coolant oil leaks or it is at a suitable level and fill it when required. Please see to "maintenance" part.
- Check whether the battery fluid leaks or it is at a suitable level and fill the distilled water when required. Please see to "maintenance" part.

Check whether the following parts or areas are damaged and whether any parts are improperly installed, loosened or missed.

- Electric parts, connecting wires and cables.
- Hydraulic hose, coupling, cylinder and counterbalance valve.
- Fuel and hydraulic tank.
- Travel motor and turning motor
- The rods and gaskets for the boom and axle.
- Tire and rim
- Engine and some related parts.
- Limit switch and horn
- Alarm and indicator light(if equipped)
- Nuts, bolts and other fastening items.

- The mid-rail or gate of platform access

Check the whole machine to find:

- Weld seam or the seam on the structural parts.
- Dents or damages on the machine
- Be sure that all the structural parts and other key parts are completed, and all the related fastening items and dowels are in right position and screwed fully.
- Be sure that all the bulkhead covers are in right position and locked fully.

5. Maintenance

Comply with and obey the following rules:

- ✓ The operators can only implement the routine maintenance items of this manual.
- ✓ According to the manufacturer's rules and specified requirements of this manual, the routine maintenance inspection must be completed by qualified maintenance technician.

5.1 Label Definition for Maintenance



NOTICE

The following signs are used in this manual to help explain the relevant meaning of usage expression. One or more signs appear in front of the maintenance procedure express different meaning as follow.



Indicate implementation of this procedure needs tools.



Indicate implementation of this procedure needs new spare parts.



Indicate the engine must be in cold status before implement this procedure.

5.2 Check the engine oil level



Keeping appropriate oil level is essential for maintaining good engine performance and service life. Operating the machines with inappropriate oil level will damage engine parts.

Shut down the engine and check oil level.
Check engine oil level gauge, add oil as required.

Lovol 1004-4Z27 engine

Oil type 15W-40

Oil type-with low temperature 10W-30

Cummins B3.3-C80 engine

Oil type 15W-40

Oil type-with low temperature 10W-30

5.3 Check the hydraulic oil level



Keeping appropriate hydraulic oil level is essential for the machine work. Hydraulic components will be damaged if hydraulic oil level is inappropriate. Inspectors can determine the position change of hydraulic oil level through routine inspections and this change may indicate problems occurred in hydraulic system.

To ensure the boom is in stowed status and then visual check the oil level gauge on the side of hydraulic oil tank.

Results: The hydraulic oil should be at the upside of oil level gauge within the scope

of 10cm.

Hydraulic oil type	
Great wall	L-HM046
SHELL	S46
TOTAL	AZOLLZ ZS 46

5.4 Check the battery



Soundness Battery condition is essential for good engine performance and safe operation. Inappropriate electrolyte liquid level or damaged cables and wiring could lead to damage of engine parts and dangerous situations.

NOTICE

Risk of electric shock Touch an electric circuit could lead to death or serious personal injury. Remove all rings, watches and other accouterments.



Risk of bodily injury There's acid in the battery. Please prevent overflow of acid in the battery and exposure of them. Neutralizing spilled acid from batteries with soda water.

- 1、 Wearing protective clothing and protective lens.
- 2、 Ensuring the connected wirings of battery cable is not corrosive.
- 3、 Ensuring the battery firmly fixed, and connected wiring of cable fastens well.
- 4、 Remove the ventilation cover of the battery.
- 5、 Check acid liquid level of the battery. Add distilled water to the bottom of the pipette of the batteries if needed. Please not to over-filled.
- 6、 Fitted with ventilation cover.

NOTICE

Adding terminal protectors and anti-corrosion sealant will help eliminate the corrosion on battery terminals and cable.

5.5 Check the engine coolant level and type



Keeping engine coolant at the appropriate level is essential for the life of the engine. Inappropriate coolant level will affect the engine's cooling capacity and damage engine components. Inspectors can determine the change of coolant liquid level through routine inspections, and this change may indicate problems occurred in cooling system.

Check the liquid level of the recycling coolant bins. Add coolant as needed.



Risks of body injuries: The liquid in the radiator is under pressure and very hot. Please be more careful when you remove the radiator cover and add liquid.

5.6 Periodical maintenance

Periodical maintenance must be implemented according to the procedures of this maintenance manual by qualified personnel who received related training.

The following described inspection and maintenance must be recorded by qualified institutions, and the records of all inspection and maintenance must keep records for four years.

If the machine has been standing idle for more than 3 months, it must undergo quarterly inspection before reuse.

5.7 Timetable

There are five types of maintenance inspection in accordance with the time schedule – daily inspection, quarterly inspection, six months' inspection, annual inspection and biennial inspection. Considering the duplicate procedures, "Scheduled maintenance procedures" and "maintenance inspection report" is divided into five sub-A, B, C, D and E. You can determine the necessary procedures combination according to the following table to implement scheduled inspections.

Inspections	Inspection table
Daily or every 8 hours	A
Quarterly or every 250 hours	A+B
Every 6 months or every 500 hours	A+B+C
Annually or every 1000 hours	A+B+C+D
Biennially or every 2000 hours	A+B+C+D+E

5.8 Maintenance & Repair Reports

Maintenance inspection report contains every type of periodical inspection checklist. Maintenance inspection reports are copied for each inspection. The reports will be kept for three years

6. Function Test



Do not operate the machine unless:

- ✓ You have mastered and practiced the safe operation rules of this machine in this operation manual.
 - 1、 To avoid dangerous situations
 - 2、 Always inspect the machine before operation.

Understand the above rules before your next step.

- 3、 Always implement function test before application.
- 4、 Check work place.
- 5、 Use the machine only according to the machine's design idea.

6.1 Basic Principle

The purpose of function test is to find faults before use the machine. Operators must follow explanations of every step to test all the function of the machine.

It is prohibit using machines with faults. The machine must be marked and stop using if any faults was found. According to the manufacturer's stipulation, only qualified technicians can repair the machine.

After the maintenance, operators must implement Inspections before operation and function inspection before using the machine.

- 1、 Choose a strong, horizontal region without barriers as test zone

6.2 For the Turntable Controller

Turn the key switch to the “ON” position

- 1、 Turn select switch to Turntable controller
- 2、 Pull out red “Emergency Stop” to “ON” position
 - **Results:** The combination of instruments will work and no error message display.
- 3、 Start the engine. (Please see to “Instruction of Operation”)

Test the “Emergency Stop”

- 4、 Press red “Emergency Stop” to “OFF” position
 - Results: Engine will be shutdown and no function can be run.
- 5、 Pull out red “Emergency Stop” to “ON” position and restart engine.

Test the machine functions

- 6、 Press Active Enable button and activate function buttons of every boom and platform.
 - Results: The function of all the booms and platform can work normally in a whole circle
- 7、 Turn select switch to the ground controller and shut down engine.

Test the auxiliary control

- 8、 Pull out red “Emergency Stop” to the “ON” position
- 10、 Press auxiliary power button at the same time and press function buttons of each boom or activate function button of each boom.

NOTICE

To save battery power, please test each function in the

segment of the circle.

- Results: All boom functions should be run.
- 9、 Press the selected button of “idle engine” until the indicate light of high idle speed was on beside activated foot pedal.

Test the hydraulic oil return filter

- 10、 Find and check the status indicator of hydraulic oil filter
- Results: When the oil filter run, the indicator light was off.

6.3 For the platform controller

Test the Emergency Stop

- 11、 Turn selective switch to platform controller.
 - 12、 Turn red “Emergency stop” switch of platform to the “OFF” position
 - 13、 Turn the switch to the platform controller
- Results: The engine will shut down and no function will run.
- 14、 Pull out red “Emergency Stop” and the engine should be restart.

Test the horn

- 15、 Press horn button.
- The horn will be ringing.

Test the footswitch

- 16、 Turn red “Emergency Stop” button to the “OFF” position
 - 17、 Turn red “Emergency Stop” button to the “ON” position but do not start the engine.
 - 18、 Press foot pedal and try to start the engine by press “start engine” button
- Results: The engine could not be activated.
- 19、 Re-start the engine without pressing foot pedal.
 - 20、 Test each function of machine without pressing foot pedal.

Result: All the functions of the machine will not run.

Test functions of the machine

- 21、 Press foot pedal

22、 Activated handles, buttons and plate of function.

- All the functions can be implementing in a complete circle.

Test the steer function

23、 Press select steering button

24、 Press foot pedal

- The square end wheel should be rotated in accordance with the chosen direction of steering button.

Test the drive and brake

25、 Please press foot pedal.

26、 Please move drive/steering control handle slowly in accordance with the direction of yellow arrow on the control panel until the machine start to move, and then return the handle to the center place.

- Result: the machine should be move in accordance with the direction of yellow arrow on the drive chassis, and then stop.

27、 Move drive/ steering control handler slowly in accordance with the direction of red arrow on the control panel until the machine start to move, and then return the handle to the center place.

- Results: The machine should be move in accordance with the direction of red arrow and then stop.

NOTICE

The brake should stop the machine smoothly on any slope it can climb.

Test the weighing system

28、 The boom is full stowed with the lowest status. Add loading to the platform gradually.

- Results: The overload indicator light starts flashing when the loading is more than 240 KG. The overload indicator light is on and horn is ringing when the loading is more than 250KG.

Test Activate drive system

29、 Press foot pedal and low the machine to the stowed status

30、 Rotate the turntable until the basic boom moves past one of the non-steer tires



- Results: The indicator light of Drive Activate should be on when the boom was locate in any position within the scope as showed in the table.

31、 Move drive/steering control handler until it deviate from the center location.

- Results: All the drive functions cannot be implementing.

32、 Press Drive Activate button and move drive/steering control handler slowly to deviate it from the center of handler.

- Results: The drive function should be able to run.

NOTICE

The machine can drive according to the opposite direction of the movement of Drive/Steering control handler when the Drive Activate system is run. You can confirm move direction by the color arrow direction on platform controller and drive chassis. If the Drive/Steering control handler does not move in two seconds after press Drive Activate button, the drive function cannot be implementing.

Test the limited drive speed

33、 Press the foot pedal.

34、 Raise the boom to the horizontal pole with 10 degrees.

35、 Move the drive control handler slowly to full-drive position.

- Results: The maximum drive speed should not exceed 0.3 M/s with the raised boom.

Note: the move speed of the machine will be 12.2 meters per 40 seconds.

36、 Low the boom to the stowed status.

37、 Extend the boom to 1.2M.

38、 Move the drive control handler slowly to full-drive position.

- Results: The maximum drive speed should not exceed 0.3meter/second with the extended boom.

Note: The move speed of the machine will be 12.2 meters per 40 seconds. If the drive speed exceed 0.3 meters per second with the raised boom or extended boom, the machine should be marked and stop using.

39、 Raise the boom to horizontal line and extend it as much as possible.

40、 Move the drive control handler slowly to the full drive position.

- Results: the maximum speed will not exceed 0.2meter per second with the full extended boom.

Note: the move speed of the machine will be 12.2 meters per 70 seconds.

Test the Auxiliary control

41、 Shut down the engine.

42、 Pull out the red "Emergency Stop" button to the "ON" position.

43、 Please press footswitch.

44、 Press Auxiliary power button at the same time and activate control handler, button switch plate or button for each function.

NOTICE

To save battery power, please test each function in segments of the circle.

- Results: All the boom and steering function will be run. Machine equipped with auxiliary power drive options: Drive function should be able to run.

7. Inspect the Workplace



Do not operate unless:

- ✓ You have mastered and practiced the safe operation rules in this operation manual.
 1. To avoid dangerous situation
 2. Always check before operation.

Please understand the above rules before your next step.

3. Always implement function test before operation.
4. Check the work place
5. Using the machine only according to the machine's design idea.

Basic Principle

“Workplace Inspection” will help operations to determine whether the workplace is fit for the safe operation of the machine. Operators should be carried out this work prior to the machine move to the workplace.

It is the operator's responsibility to understand and remember the issue of risk in workplace. Operations may pay attention and avoid these problems when move, install and operate the machine.

Workplace Inspections

Be careful and avoid the emergence of the following dangerous situations:

- Steep slopes or caves.
- Protruding objects, ground barriers or debris.
- Air barrier and high-voltage wires
- Dangerous position
- Surface that cannot support all loads imposed by the machine.

- Wind and atmospheric conditions
- Emergency of unauthorized personnel
- Other unsafe situations that may occur.

8. Operation Preconditions



Do not operate the machine, unless

- You've known about the safe operation rules stipulated in this operational manual and put it into practice already.

1. To avoid dangerous cases
2. Always conduct check-up before the operation

Know and understand the above rules before you go ahead with this manual.

3. Always conduct performance-test before the use.
4. To check up the work site.
5. Only use this machine as per its designed intention

Basic rules

“Operation Manual” provides detailed guidelines for each machine performance. It's the operator's duty to obey the operational manual and safety guidelines

Except for sending human and tools to the height, all the others purpose is not safe and will lead to danger situations.

Only well trained and authorized people can be permitted to operate the machine. If more than one people in different working shift operate the machine in different working time, then all of them must be qualified operator and to obey all the operational manual and all the safety guidelines, which means the checking up before start, performance test and checking up work site should all be done before each operator starts the machine.

Start engine

- Turn the key to “ON” position on the rotation controller.
- Ensure the red “Emergency Power Offer” button, both on the rotation controller and platform controller, was pulled out to “ON” position
- Press the switch to start the engine. If engine failed to start or down, then press the start switch one more time, and the interval must be longer than three seconds.

If still failed 15 minutes after the starting, please define the root causes and fix any problems. Another 60 seconds should be waited before one more try of starting.

All models applied: when in extremely lower temperature, -30°C or even lower, the engine should be pre-heated for a 5-minuts to pretend the hydraulic system from ruining.

Emergency stop

Position to the red button of “Emergent Power Off” on ground or on platform to the “Off”, stop all the functions and power off the engine.

Auxiliary control

In case of any engine failure, please use the auxiliary power

- Turn the switch to ground or platform controller.
- Pull out the red emergency stop button to “ON” position.
- Step on the footswitch when operating the auxiliary controller.
- Press the auxiliary power button and start required function. The machine equipped with the auxiliary drive options can be operated the functions of the boom and platform.

Operation on the ground

- Turn the switch to ground controller.
- Pull the red emergency stop button to “ON” position.
- Start the engine.

Operation on the platform

- Turn the switch to platform controller.
- Step on the footswitch. Follow the instruction on the control panel, slowly move the function control joystick, or toggle switch, or the related button.

Driving or steering function can not be achieved through platform controller.

Steering

- Press footswitch.
- Press steering button when selecting steering direction.

The colorful direction arrow on the platform controller and on the driven chassis helps to define the direction of steering.

Driving

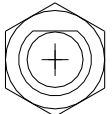
- Press footswitch.
- To build up speed: press  yellow or red arrow direction to driving.
- To lower down speed: to move toward central position or steering control joystick.
- Stop: turn the steering/driving control joystick back to the center position or release the footswitch.

To identify the machine heading direction is by the color direction on platform controller or driving chassis.

Machine driving speed will be restricted when boom lifting or extending.

Engine idle speed selection

Press selection button to select the engine idle (rotation/minute), the indicative lamp will turn on.

Symbol of Rabbit: high engine idle

Symbol of Tortoise: low engine idle

Check up engine indicative lamp

Upon the indicative lamp turning on, please check up the oil and cooling liquid for the engine.

Flashing buzzer and indicative lamp

- Flashing buzzer is constant on indicate the operator approaching the max. range or beyond lifting limit.
- “Indicative signs: when the lifting weight is above 240kg the overloading lamp will flash, when is above 250kg, the overloading lamp platform lifting limit
- Machine Un-leveling indicator: when the machine un-leveling indicator is on, the machine is positioned on an uneven ground. The boom extension and lifting more than 12° will be prohibited. Please move the machine to solid even ground.
- Platform Un-leveling indicator: when the platform un-leveling indicator is on, the platform is positioned un-leveling. Leveling the platform until the lamp is off.
- Fuel volume alarm indicator: this lamp will be on to indicate too little fuel. Add

more fuel immediately.

- Circuit Failure indicator: the lamp will be on to indicate circuit failure or sensors problem.
- Power indicator: turn on the light, and then the lamp is constantly on.

Stop the engine

Press the red “Emergency Stop” button and turn the key to OFF position.

Everytime after machine use

- Pause the machine in a safe place, could be solid leveling ground surface, without obstacles and busy transportation.
- Boom retracted and lowered to stowed position.
- Turn the rotation with the boom right between the non-steer tires.
- Turn the key to OFF position and un-plug the key, to avoid unauthorized usage.
- Lock the wheels.

9. Lifting and transportation



When being transported below rules must be followed:

- Transport vehicle must be paused on the leveling ground.
- When loading, the transport vehicle must be fixed to avoid rolling.
- Ensure the transport vehicle volume, loading surface, fasten belt or rigging enough to support the machine weight. (the weight refers to the specification)
- Ensure the front wheel has been locked by rotation lock; unlock when start to operate the machine.

Ensure safe transport by truck or trailer

- Using rotation lock when transport the machine every time.
- Always lock the machine wheels for transportation.
- Fixed the machine on the transport surface through the fastening point on the chassis.
- Use chain or belt strong enough.
- Turn the key to “OFF” position before transportation and unplug the key.
- Fully check the machine to ensure no loose or unfixed parts.

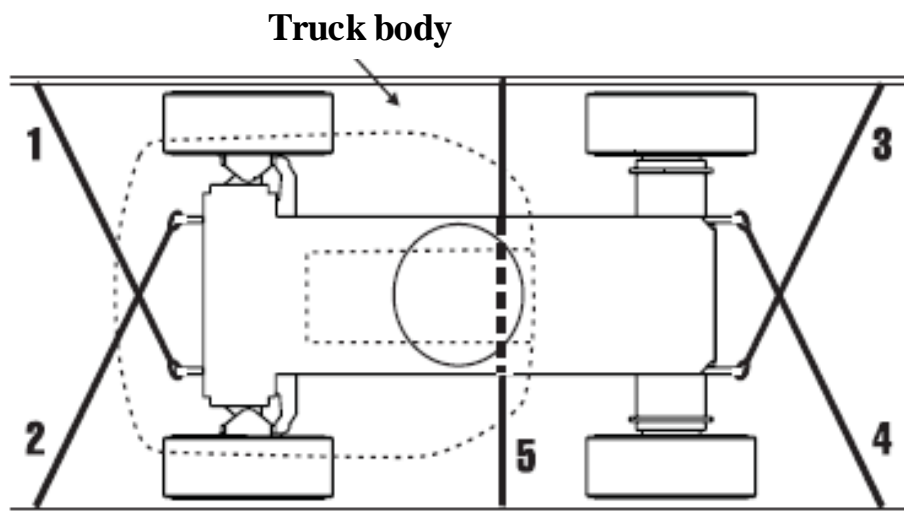

Lifting instructions

Completely lower and extract the boom.

Fix the rotation by locking the rotator

Attaching the rigging to appointed lifting hole, with two on the chassis, and two on the rotation.

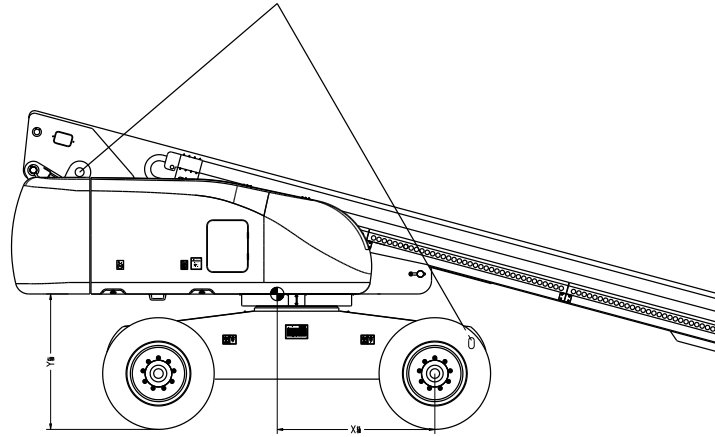

	X Axle	Y Axle
GTBZ28	1500mm	1230mm

10. Label

Check the label stick

Check the label stick properly or not as per below table and demonstration.

Serial	Description	Qty
1	No Climbing	1
2	No Climbing on the Alarm board	1
3	No Standing under the boom	1
4	No working on slope and max load for each tire is 10000kg.	4
5	Not insulated, keep away from circuit	2
6	Lifting point	4
7	No Smoking and Flame	1
8	Ware glove, anti-slip shoe, safety helm, safety belt	1
9	Safety Belt	2
10	Platform Rated Load	1
11	Footswitch	1
12	Operation Direction	1
13	Safety Belt	2
14	Max Force for Working on Platform	1
15	Operation Direction	1
16	Keep away from circuit line when working, no operation when wind speed is above level-6 or 13m/s, observation on underside and flat ground surface is needed when lowering the platform	1
17	Label	1
18	Direction for machine moving forward	1
19	Direction for machine moving rearward	1

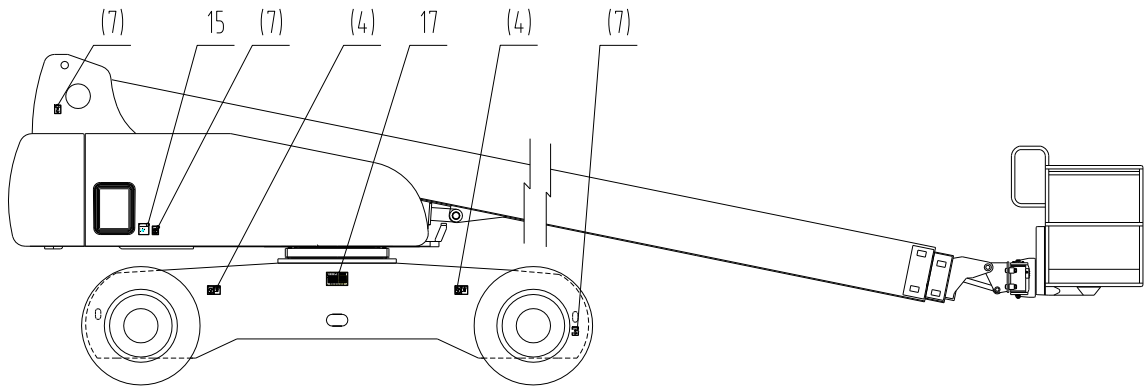
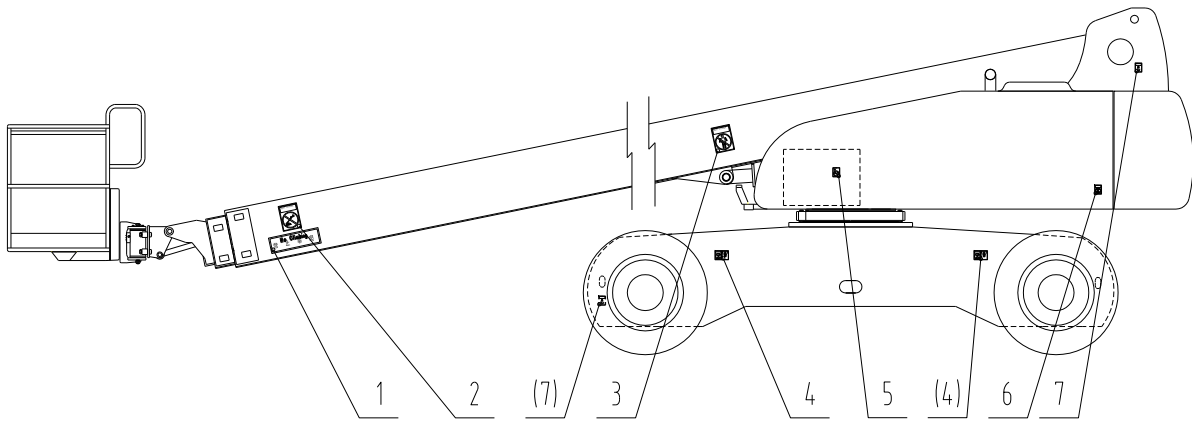

Chassis

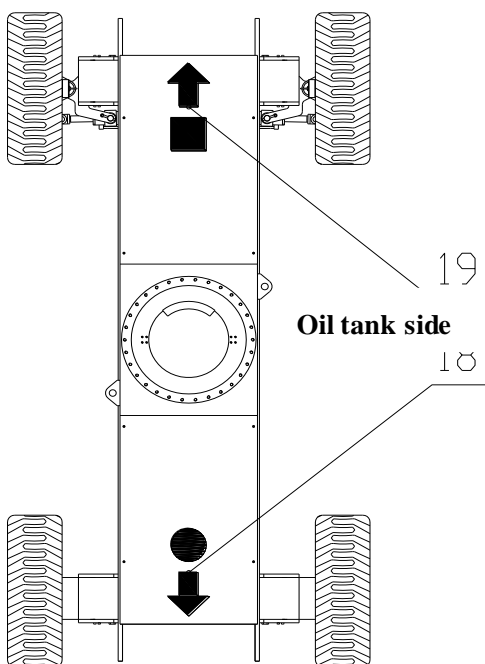

Platform control

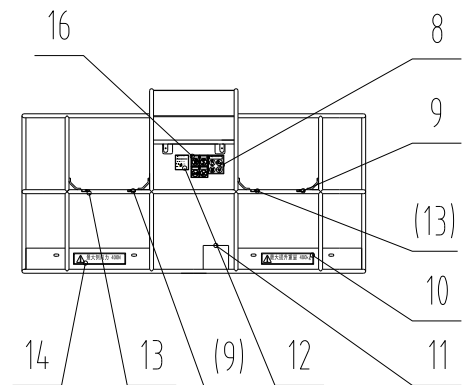

GTBZ28	
Max Working height	30.1m
Max Platform height	28.1m
Max Height-Stowed	2.8m
Max Horizontal reach	20.1m
Width	2.75m
Length-Stowed	12.4m
Max Platform Capacity	250kg(unlimited) 480kg(limited)
Wheelbase	3m
Turning radius(outside)	6.07m
Turning radius(inside)	2.46m
Turntable rotation	360°continuous
Turntable tailswing	1.18m
Driving Speed (Stowed)	5.2km/h
Driving Speed (raised or extended)	1.1km/h
Platform size (L*W*H)	1.83m×0.76m×1.1m
Platform rotation	160°
Max Hydraulic pressure (drive function)	210MPa
System voltage	24V
Tire size	12.00-20/solid
Grade ability(stowed)	2WD 30% 4WD 45%
Ground clearance	0.33m
Fuel tank capacity	125L
Weight	2WD-16300kg 4WD-16370kg